

# S100 series

## Ø100mm Bulb Revolving Signal Light

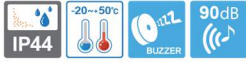

S100R



### Common Specifications(S100R/ S100U/ S100UA/ S100M)

- Ø100mm general-purpose bulb revolving signal lights
- Adopts a special power transmission system that reduces noise and wear
- Built-in buzzer available (Volume : max 90dB at 1M)
- Revolving speed : 120-140RPM
- Material : Lens-AS, Housing-ABS, Reflector-Heat resistant ABS
- Ambient operating temperature : -20°C to +50°C

### S100R Bulb Revolving Signal Light

- Protection rating : IP 44
- Certificates : CE Compliant

Model number	Voltage	Current	Bulb			Certificates	Weight	Color
			Spec	Standard	Parts no			
S100R	DC12V	0.966A	12V10W	T16x35 15S	9	CE	0.34kg	<ul style="list-style-type: none"> <li>• R-Red</li> <li>• A-Amber</li> <li>• G-Green</li> <li>• B-Blue</li> </ul>
	DC24V	0.566A	24V10W	T16x35 15S	10		0.34kg	
	AC110V	0.130A	12V10W	T16x35 15S	9		0.60kg	
	AC220V	0.065A	12V10W	T16x35 15S	9		0.60kg	

### Technical Diagram

(Units : mm)

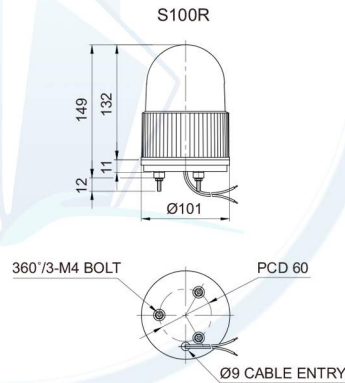

### Wiring Instructions

- External power line standard : UL1015 AWG18(0.75sq)×2C 400mm
- DC type : Black output line is negative(-)

### Customization

- Efficient type with AC bulb (Model number : S100E)
- FT bracket equipped (Model number : S100E-FT)
- Wall mount bracket : Power line threading the bracket hole or into the wall mount

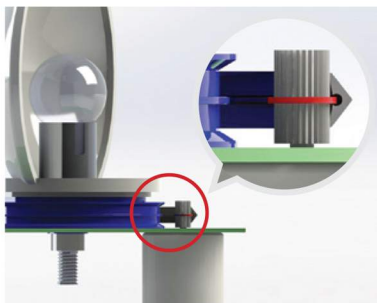

**V belt type power transfer system feature**  
Designed to minimize the abrasion of the belt, and to efficiently deliver torque from the drive shaft to the reflector. (Patent registered)

### Ordering Specification

S100R	-	BZ	-	24	-	R
[Model number]		[Buzzer option]		[Voltage]		[Color]
• S100R		<ul style="list-style-type: none"> <li>• None</li> <li>- No buzzer</li> <li>• BZ</li> <li>- Built-in buzzer</li> </ul>		<ul style="list-style-type: none"> <li>• 12-DC12V</li> <li>• 24-DC24V</li> <li>• 110-AC110V</li> <li>• 220-AC220V</li> </ul>		<ul style="list-style-type: none"> <li>• R-Red</li> <li>• A-Amber</li> <li>• G-Green</li> <li>• B-Blue</li> </ul>