

# S125 series

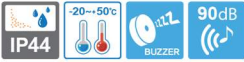

## Ø125mm Bulb Revolving Warning Lights



S125U



### S125U Bulb Revolving Warning Light

- Protection rating : IP44

| Model number | Voltage | Current | Bulb   |            |          | Certificates | Weight | Color     |
|--------------|---------|---------|--------|------------|----------|--------------|--------|-----------|
|              |         |         | Spec   | Standard   | Parts no |              |        |           |
| S125U        | DC12V   | 0.966A  | 12V10W | T16x35 15S | 9        | -            | 0.41kg | • R-Red   |
|              | DC24V   | 0.566A  | 24V10W | T16x35 15S | 10       |              | 0.41kg | • A-Amber |
|              | AC110V  | 0.130A  | 12V10W | T16x35 15S | 9        |              | 0.65kg | • G-Green |
|              | AC220V  | 0.065A  | 12V10W | T16x35 15S | 9        |              | 0.65kg | • B-Blue  |



### Technical Diagram

(Units : mm)

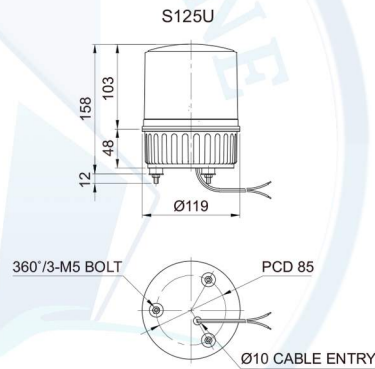

### Wiring Instructions

- External power line standard : UL1015 AWG18(0.75sq)×2C 400mm
- DC Type : Black output line is negative(-)



### Customization

- 2 buzzer sound types : Both prolonged (beep, beep) and staccato (beep, beep, beep) buzzer output available
- Wall mount bracket options : Bracket structure allows for threading through the bracket hole or into the wall mount



Wall Mount Bracket SWP125



Wall Mount Bracket SWM125



CNC machine equipped with S125U



### Ordering Specification

| S125U          | - | BZ   | - | 220  | - | R   |
|----------------|---|--|---|--|---|---|
| [Model number] |   | [Buzzer option]                                    |   | [Voltage]  |   | [Color]                                       |
| • S125U        |   | • None<br>- No buzzer<br>• BZ<br>- Built-in buzzer |   | • 12-DC12V<br>• 24-DC24V<br>• 110-AC110V<br>• 220-AC220V |   | • R-Red<br>• A-Amber<br>• G-Green<br>• B-Blue |