

CXH 5-2 marine durable headlight navigation corrosion resistant signal light

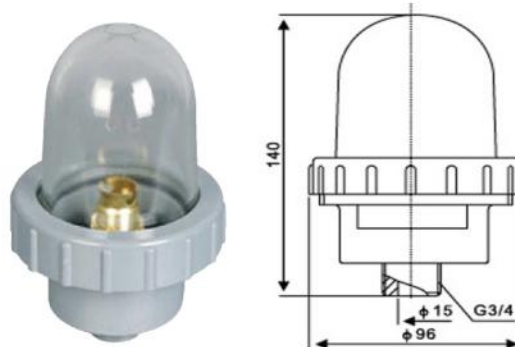

The scope of application

Applied to the ships as lamp signal when night navigation
Products characteristic

1. Screw-type connecting flange, it is convenient to install and replace the bulb
2. The lampshade adopts good quality pyrex glass, and it has good function of pervious to light

Adopt standard

1. Conform to (THE INTERNATIONAL REGULATIONS FOR PREVENTING COLLISION AT SEA.1972) and (GRADE ENTRY NORMS FOR STEEL SHIPS)
2. Conform to the standard of marine electric signal light's technical condition GB/T 3028-1995
Production authentication
approved by CCS (China Classification Society), and ZY of China Fishery Inspection

规格: Specification

型号Type	可见距离 Visibility	水平光弧 Level arc	灯座 Lamp holder	电压 Voltage	功率 Power	防护等级 Protection class	电缆外径 Cable outside diameter	颜色 Color	材质 Material	重量 Weight
CXH5-1	3n.m	360°	E27	24V	60W	IP56	φ 12	明 transparent	铝aluminium	0.9Kg
CXH5-1A				110V				红 Red 绿 Green 黄 yellow 蓝 blue 紫 purple		
CXH5-2	2n.m	360°	B15d	24V	30W			明 transparent	铝aluminium	0.4Kg
CXH5-2A				24V	30W			红 Red 绿 Green 蓝 blue		
CXH5-3	2n.m	360°	B15d	12V 24V	15W			明 transparent 绿 Green 红 Red	塑料Plastic	0.3Kg