

Double-deck Navigation Light Series 70

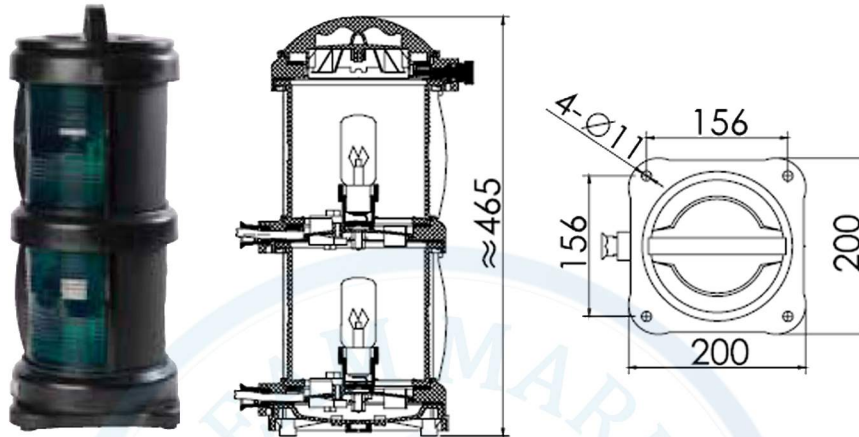

Products feature :

1. This lamp can be installed conveniently and its bulb can be replaced easily. It can replace the bulbs after opening the top cover.
2. There are automatic leak holes on the bottom of the light.
3. The shell adopts high-strength engineering plastic with watertight, good corrosion resistance, impact resistance and other characteristics.
4. The lampshade adopts Poly carbonate material which has the feature of ultraviolet radiation resistance and non-discoloring.
5. The signal lights adopt the signal light's bulb which conforms to the ship norm and the average life not less than 700 hours.
6. The signal lights can work normally under the temperature $-30^{\circ}\text{C} \sim +50^{\circ}\text{C}$.
7. Cable outside diameter < 10mm.

The scope of application:

This light fits for the ships with the length 50m or above 50m as lamp signal communication when night navigation.

Adopt standard and products certification:

1. Conform to INTERNATIONAL REGULATIONS FOR PREVENTING COLLISIONS AT SEA 1972.
2. Conform to international standard of IEC60598-1-2008.
3. Conform to performance standard of requirement about IMO Res.MSC.253(83).
4. Conform to national standard of GB/T3028-2012.
5. Conform to RULES FOR CLASSIFICATION OF SEA-GOING STEEL SHIPS.
6. Approved by China Classification Society (CCS) and Type Approval of China Fishery Inspection Bureau. (ZY)
7. Passed the European Union (CE) certification.

Protection Class: IP56

TYPE	DISC:	VISIBILITY	LEVEL ARC	WEIGHT	LAMP HOLDER	COLOR	DM CODE
CXH3-101P	MASTHEAD WHITE DOUBLE	6n.m	225°	4.15KG	P28s	TRANSPARENT	B4607021
CXH2-101P	PORT RED DOUBLE	3n.m	112.5°	4.15KG		RED	B4607022
CXH1-101P	STBD GREEN DOUBLE	3n.m	112.5°	4.15KG		GREEN	B4607023
CXH4-101P	STERN WHITE DOUBLE	3n.m	135°	4.17KG		TRANSPARENT	B4607024
CXH4-101P	TOWING YELLOW DOUBLE	3n.m	135°	4.17KG		TRANSPARENT YELLOW	B4607025
CXH6-101P	SIGNAL WHITE 360deg DOUBLE	3n.m	360°	4.00KG		TRANSPARENT	B4607026
CXH6-101P	SIGNAL RED 360deg DOUBLE	3n.m	360°	4.00KG		RED	B4607027
CXH6-101P	GREEN 360deg DOUBLE	3n.m	360°	4.00KG		GREEN	B4607028